



千航锂电
QIANHANG LITHIUM BATTERY

PRODUCT SPECIFICATION

Version:

A

DATE:

2020-02-18

No:

For Any Detail and question, Please Tel Sales :(+86)015855527318

CUSTOMER NO: _____

Specification Approval Sheet 规格确认书

MODEL/型号: GSP34135192F

(100Ah 3.2V)

Prepared By/Date 编制/日期	Checked By/Date 审核/日期	Approved By/Date 批准/日期
雷斌		

Customer Approval 客户确认	Signature/签字	Date/日期
	Company Name/公司名称	
	Company Stamp/公司印章	



PRODUCT SPECIFICATION

Version:

A

DATE:

2020-02-18

No:

For Any Detail and question, Please Tel Sales: (+86)015855527318

Amendment Records/修正记录

Revision 版本	Description/记述	Prepared by 编制	Approved by 批准	Date/日期
A	First Publish	雷斌		2020-02-18



PRODUCT SPECIFICATION

Version:

A

DATE:

2020-02-18

No:

For Any Detail and question, Please Tel Engineer: **(+86)015855527318**

Content/目录

1. Scope/适用范围	Page 4
2. Model/型号	Page 4
3. Cell Specification/电芯规格说明	Page 4
4. Battery/Cell performance test Criteria/电池性能标准	Page 5
4.1 Appearance inspection by visual/外观目测	Page 5
4.2 Environmental test condition/外界环境条件	Page 5
4.3 Electrical characteristics/电气特性	Page 5
4.4 Mechanical characteristics/机械特性	Page 6
4.5 Safety performance/安全性能	Page 7
5. Cell initial Dimensions/电芯初始尺寸	Page 8
6. Notice for Assembling Battery Pack 电池装配注意事项	Page 9
7. Others/其它	Page 9
7.1 Cell connection/电池连接	Page 9
7.2 Prevention of short circuit within a battery pack/电池内部的短路预防	Page 9
7.3 Prohibition of disassembly/禁止拆卸	Page 9
7.4 Prohibition of dumping of cells into fire/不要把电池倾倒在火中	Page 10
7.5 Prohibition of cells immersion into liquid such as water/禁止浸泡电池	Page 10
7.6 Battery cells replacement/更换电池	Page 10
7.7 Prohibition of use of damaged cells/禁止使用损坏的电	Page 10
8. Period of Warranty/保质期	Page 10
9. Storage of the Batteries/电池的存放	Page 10
10. Other The Chemical Reaction/其它化学反应	Page 10
11. Note/注释	Page 11



PRODUCT SPECIFICATION

Version:

A

DATE:

2020-02-18

No:

For Any Detail and question, Please Tel Sales: (+86)015855527318

1 Scope/适用范围

This specification is applied to describe the related Battery product in this Specification and the Battery/cell supplied by Great Power Battery Co., Ltd only.

本说明书只适用于描述本规格书中相关的产品以及鹏辉电池有限公司提供的电池。

2 Model/型号: GSP34135192F_100Ah

3 Cell Specification/电芯产品规格

No.	Items/项目	Specifications/规格		Remark 备注
1	Nominal Capacity 标称容量	100Ah		0.5C Standard discharge 0.5C 标准放电
2	Delivery Capacity 交货容量	≥100Ah		
3	Nominal Voltage 标称电压	3.2V		Mean Operation Voltage 即工作电压
4	Charge Voltage 充电电压	2.5~3.65V		
5	Standard charging current 标准充电电流	0.5C		0.5C constant current, 3.65V constant voltage charge to 3.65V, continue charging till current decline to ≤0.05C 0.5C 恒流 3.65V 恒压充至电流≤0.05C
6	Standard discharging current 标准放电电流	0.5C		
7	Max. discharging current 最大放电电流	1.0C		
8	Max. pulse discharging current 最大脉冲放电电流	2.0C		30s
9	Cell Internal Impedance 单电芯内阻	≤0.8mΩ		1kHz; 2%SOC
10	Operation Temperature and relative humidity Range 工作温度和湿度范围	Charge/充电	0~50℃ 60±25%R.H.	Charge at a very low temperature such as below 0℃, will be get a lower capacity and reduce cycle life of the battery 低温充电效率会下降, 会影响电池使用寿命
		Discharge/放电	-20~55℃ 60±25%R.H.	
11	Storage temperature for a long time 长时间储存温度	-20~55℃ 60±25%R.H.		Do not storage exceed half year. Must charge once when storage for half year. Must charge the battery which with protect circuit when storage for three mouths. 不可超过半年,达到半年须充电一次 带保护板电池3个月充电一次



千航锂电

QIANHANG LITHIUM BATTERY

PRODUCT SPECIFICATION

Version:

A

DATE:

2020-02-18

No:

For Any Detail and question, Please Tel Sales:(+86)015855527318

4 Battery/Cell performance test Criteria/电池性能标准

4.1 Appearance inspection by visual/外观目测

There shall be no such defect as flaw, crack, rust, leakage, which may adversely affect commercial value of battery.

电池外观应没有裂纹、爆裂、锈渍、污渍、漏液等影响商业价值的缺陷存在。

4.2 Environmental test condition/外界环境条件

Unless otherwise specified, all test stated in this product specification are conduct at below test condition

所有测试应按以下环境条件进行，除非特殊指定外。

Temperature: 20°C~30°C

Relative Humidity:60%±25% R.H.

4.3 Cell Electrical characteristics/电气特性

No	Items/项目	Test Method and Condition/测试方法及条件	Criteria/标准	
1	Rated Capacity at 0.5C(Min.) 0.5C 最小额定容量	After standard charge, the capacity shall be measured on 0.5C discharge till the voltage discharge to 2.5V, 标准充电后，放电至 2.5V 截止，测量 0.5C 放电容量	≥100Ah	≥100%
2	Cycle Life 循环寿命	Charging and discharging battery as blew conditions 0.5C standard charge to 3.65V end-off 1.0C standard discharge to 2.5V cut-off Continuous charge and discharge for 2000 cycles, the capacity will be measure after the 2000 th cycle 充放电按以下条件： 0.5C 标准充电至 3.65V，1.0C 标准放电至 2.5V，连续充放电循环 2000 周，在第 2000 周结束后测量容量	≥80% of initial capacity	
3	Capacity retention & recovery 容量保持及恢复	The battery to be charge in accordance with standard charge condition at 25±5°C,then storage the battery at an ambient temperature 25±5°C for 28 days. Measure the capacity after 28 days with 0.5C at 25±5°C 将电池在 25±5°C 标准充电后储存在 25±5°C 的环境中 28 天，28 天后，测试电池在 25±5°C 环境下 0.5C 容量	容量保持≥95% 容量恢复≥97%	



PRODUCT SPECIFICATION

Version:

A

DATE:

2020-02-18

No:

For Any Detail and question, Please Tel Sales: (+86)015855527318

4.4 Mechanical characteristics/机械特性

No	Items/项目	Test Method and Condition/测试方法及条件	Criteria/标准
1	Free fall test 自由跌落测试	The battery to be fully charged in accordance with standard charge condition, then drop the battery which the positive and negative extremes face down from a height of 1,5m onto a concrete floor, observing for 1h. 电池按照标准充电条件充满电, 然后电池正负极端子朝下从1.5m高度跌落到一个水泥地面, 观察1h。	No explosion, No leakage, No fire 无泄漏, 不起火, 不爆炸
2	Vibration test 振动测试	After standard charging, fixed the cell to vibration table and subjected to vibration cycling that the frequency is to be varied at the rate of 1Hz per minute between 10Hz and 55Hz, the excursion of the vibration is 1.6mm. The cell shall be vibrated for 30 minutes per axis of XYZ axes. 将标准充电后的电芯固定在振动台上, 沿 X、Y、Z 三个方向各振动 30 分钟, 振幅 1.6mm, 振动频率为 10Hz~55Hz, 每分钟变化 1Hz。	No explosion, No leakage, No fire 无泄漏, 不起火, 不爆炸
3	Crush test 挤压测试	Fully charged the battery in accordance with standard charge condition, the battery is to be crushed between a flat plate and a 75mm semicylinder, the length of the semicylinder should greater than the size of the cell. The extrusion speed is 5 ± 1 mm/s, Continuous to applied force on battery, stopped until a pressure reading of 200K N is reached on the hydraulic ram or the cell voltage reaches at 0V or the deformation quantity reaches at 30%, observing 1h. 电池按标准充电条件充满电, 放置在一块平面金属板与一块 75mm 的半圆柱体之间, 持续加压, 直到液压缸施加的压力达到 200KN 或电池电压为零或形变量达到 30%时停止, 观察 1h。	No explosion, No fire 无起火, 无爆炸



PRODUCT SPECIFICATION

Version:

A

DATE:

2020-02-18

No:

For Any Detail and question, Please Tel Sales:(+86)015855527318

4.5 Safety performance/安全性能

No	Items/项目	Test Method and Condition/测试方法及条件	Criteria/标准
1	Thermal exposure test 高温热冲击测试	Each fully charged cell, stabilized at room temperature, is placed in a circulating air-convection oven. The oven temperature is raised at a rate of 5 °C/min ± 2 °C/min to a temperature of 130 °C ± 2 °C. The cell remains at this temperature for 30 min before the test is discontinued, observing for 1h. 充满电的电池温度稳定到常温后, 放置入循环空气烘箱里, 从常温以 5 °C/分± 2 °C/分的速率升至130°C后, 在130°C放置30分钟, 观察1h	No explosion, No leakage, No fire 无泄漏,不起火, 不爆炸
2	Low pressure 低压测试	Each fully charged cell is placed in a vacuum chamber, in an ambient temperature of 25±5°C. Once the chamber has been sealed, its internal pressure is gradually reduced to a pressure equal to or less than 11,6 k Pa (this simulates an altitude of 15240 m) held at that value for 6 h. 电池放在一个模拟真空的空间放置6小时, 环境温度为25±5°C., 真空环境压力≤11.6kpa,模拟15240m高空低压环境	No explosion, No leakage, No fire 无泄漏,不起火, 不爆炸
3.	Short test 短路测试	The fully charged battery is to be short-circuited by connecting the positive and negative terminals of the battery with resistance load not exceed 5m Ω for 10min.Tests are to be conducted at room temperature 25±5°C,observing for 1h. 在室温 25±5°C把充满电的电池的正负极用不超过 5m Ω 的负载连接起来 10min., 连接起来使电池外部短路,观察 1h.	No explosion, No fire 无起火,无爆炸
4	Forced discharge test 过放电测试	A fully charged cell discharged at 1C for 90 min,observing 60min. 将满电电池, 1C 持续放电 90 分钟, 观察 1h	No explosion, No leakage, No fire 无泄漏,不起火, 不爆炸
5	Over charge test 过充电测试	After standard charge, continue to charge with a constant 1C current until the voltage reaches 1.5 times the standard cut-off voltage or charging time reaches 1h. Observing for 1H. 电芯标准充满电后, 1C 持续充电直到电压达到标准截止电压的 1.5 倍或充电时间达到 1h,观察 1h.	No explosion, No fire 无爆炸, 无起火
6	Soak Test 浸泡测试	Put the fully charged battery into 3.5% NaCl solution, be soaked for 2 hours. 把电池放进 3.5%NaCl 溶液中浸泡 2 个小时	No explosion, No fire 无爆炸, 无起火



PRODUCT SPECIFICATION

Version:

A

DATE:

2020-02-18

No:

For Any Detail and question, Please Tel Sales: (+86)015855527318

5 Cell initial Dimensions/电芯初始尺寸

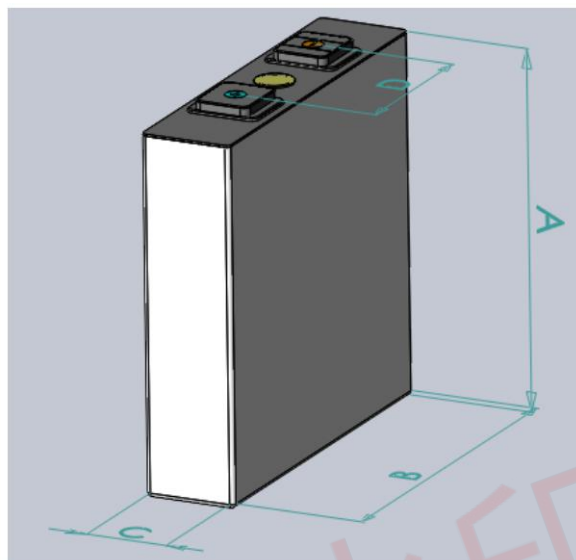

NO	Items	Units: mm	Remark
1	C/厚度	≤ 37.5	电芯自由状态
2	B/宽度	135 ± 1.0	
3	A/高度	192 ± 1.0	
4	D/极柱间距	89 ± 0.5	
5	重量	$\leq 2.03\text{Kg}$	



PRODUCT SPECIFICATION

Version:

A

DATE:

2020-02-18

No:

For Any Detail and question, Please Tel Sales :(+86)015855527318

6 Notice for Assembling Battery Pack 电池装配注意事项

Shocks, high temperature, or contacts of sharp edge components should not be allowed in battery pack assembling process.
在电池装配过程中不允许撞击、高温或接触尖锐部分。

7 Others/其它

7.1 Cell connection/电池连接

- 1) Direct soldering of wire leads or devices to the cell is strictly prohibited.
- 2) Lead tabs with pre-soldered wiring shall be spot welded to the cells.

Direct soldering may cause damage of components, such as separator and insulator, by heat generation.

- 1) 严禁直接焊接引线或设备到电池上。
- 2) 极片在焊接引线之前应该先点焊到电池上，直接与电池热焊接，产生的热量会使电池的隔离体及绝缘体受损。

7.2 Prevention of short circuit within a battery pack/电池内部的短路预防

Enough insulation layers between wiring and the cells shall be used to maintain extra safety protection. The battery pack shall be structured with no short circuit within the battery pack, which may cause generation of smoke or firing.

在电池和引线之间应该有足够的绝缘层用于安全保护。电池的包装构成应没有导致起烟起火的短路情况。

7.3 Prohibition of disassembly/禁止拆卸

- 1) Never disassemble the cells

The disassembling may generate internal short circuit in the cell, which may cause gassing, firing, explosion, or other problems.

- 2) Electrolyte is harmful

LIP battery should not have liquid from electrolyte flowing, but in case the electrolyte come into contact with the skin, or eyes, physicians shall flush the electrolyte immediately with fresh water and medical advice is to be sought.

- 1) 不要拆卸电池。
拆卸电池会发生电池内部短路，会引起起火、爆炸、有害气体或者其它问题。

- 2) 电解液是有害的

万一电解液沾到皮肤、进入眼睛，应立即用清水冲洗以及求助医生。



PRODUCT SPECIFICATION

Version:

A

DATE:

2020-02-18

No:

For Any Detail and question, Please Tel Sales: **(+86)015855527318**

7.4 Prohibition of dumping of cells into fire/不要把电池倾倒在火中

Never incinerate nor dispose the cells in fire. These may cause explosion of the cells, which is very dangerous and is prohibited.

不要焚毁电池，否则会致电池爆炸，这个很危险，必须禁止。

7.5 Prohibition of cells immersion into liquid such as water/禁止浸泡电池

The cells shall never be soaked with liquids such as water, seawater, drinks such as soft drinks, juices, coffee or others.

请不要把电池浸泡在液体当中，像清水、海水，及非酒精饮料、果汁、咖啡或者其它的饮料。

7.6 Battery cells replacement/更换电池

The battery replacement shall be done only by either cells supplier or device supplier and never be done by the user.

更换电池应由电池生产商或设备供应商完成，用户不要自行更换。

7.7 Prohibition of use of damaged cells/禁止使用损坏的电池

The cells might be damaged during shipping by shock. If any abnormal features of the cells are found such as damages in a plastic envelop of the cell, deformation of the cell package, smelling of an electrolyte, an electrolyte leakage and others, the cells shall never be used any more.

The Cells with a smell of the electrolyte or a leakage shall be placed away from fire to avoid firing or explosion.

电池可能在出货途中碰撞而受损。如果发现电池有异常，例如包装损坏、电池包裹变形，有电解液的味道、发现漏液等等，不要再使用这些电池。电池如果有电解液的味道或者出现漏液，电池放置应该远离火源避免起火及爆炸。

8 Period of Warranty/保质期

The period of warranty is 3 years from the date of shipment. Great Power guarantees to give a replacement in case of cells with defects proven due to manufacturing process instead of the customer abuse and misuse.

电池的保质期从出货之日算起为 3 年。如果电池的缺陷是在制造过程中形成的而不是由于用户滥用及错误使用造成，本公司负责退换电池。

9 Storage of the Batteries/电池的存放

The batteries should be stored at room temperature, charged to about 30% to 50% of capacity.

We recommend that batteries be charged about once per half a year to prevent over discharge.

电池应当在室温下存放，应充到 30%至 50%的电量。如长时间储存，建议每半年充一次电以防止电池过放电。

10 Other The Chemical Reaction/其它化学反应



千航锂电
QIANHANG LITHIUM BATTERY

PRODUCT SPECIFICATION

Version:

A

DATE:

2020-02-18

No:

For Any Detail and question, Please Tel Sales: **(+86)015855527318**

Because batteries utilize a chemical reaction, battery performance will deteriorate over time even if stored for a long period of time without being used. In addition, if the various usage conditions such as charge, discharge, ambient temperature, etc. are not maintained within the specified ranges the life expectancy of the battery may be shortened or the device in which the battery is used may be damaged by electrolyte leakage. If the batteries cannot maintain a charge for long periods of time, even when they are charged correctly, this may indicate it is time to change the battery.

由于电池是利用化学反应的原理，所以随着时间的增加电池的性能会降低，即使是存放很长一段时间而不使用。如果使用条件如充电、放电及周围环境温度等情形不在指定的使用范围内，会使缩短电池的使用寿命，或者会产生漏液导致设备损坏。如果电池长周期不能充电，即使充电方法正确，这样需要更换电池了。

11 Note/注释

Any other items which are not covered in this specification shall be agreed by both parties.

本说明书未包括事项应由双方协议确定。

试用水印